

# SPECIFICATIONS: HEAVY DUTY 36" PYXEL HULLER

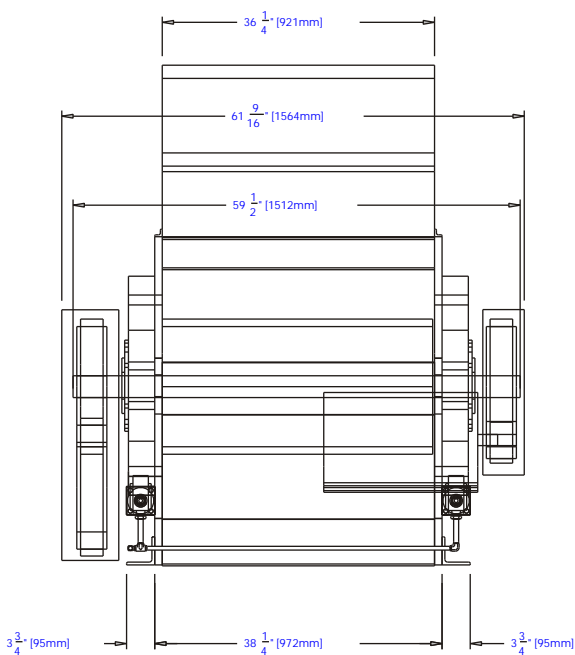
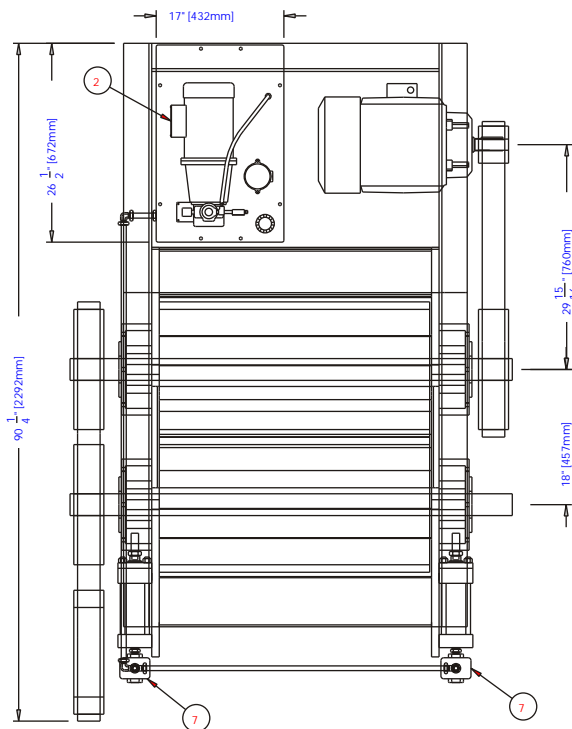

1] MAIN DRIVE MOTOR - 25HP 1450/1750RPM, 380/230/460V 50/60HZ

2] HYDRAULIC MOTOR - 2HP 1000/1200RPM, 380/230/460V 50/60HZ

3] FEEDER MOTOR - 1HP 90V DC

4] BELTS - PRIMARY 5V-6 GROOVE - SECONDARY "CC" - 4 GROOVE

5] REPLACEABLE HULLER KNIVES 19 PER CYLINDER 38 TOTAL

7] HYDRAULIC SAFETY ROLL RELIEF SYSTEM

8] DUAL 18" DIA. X 36" HULLING CYLINDERS

9] SHIPPING WEIGHT: 7800 LBS / 3538 KG

10] SHIPPING VOLUME: 160 FT<sup>3</sup> / 4.5 M<sup>3</sup>

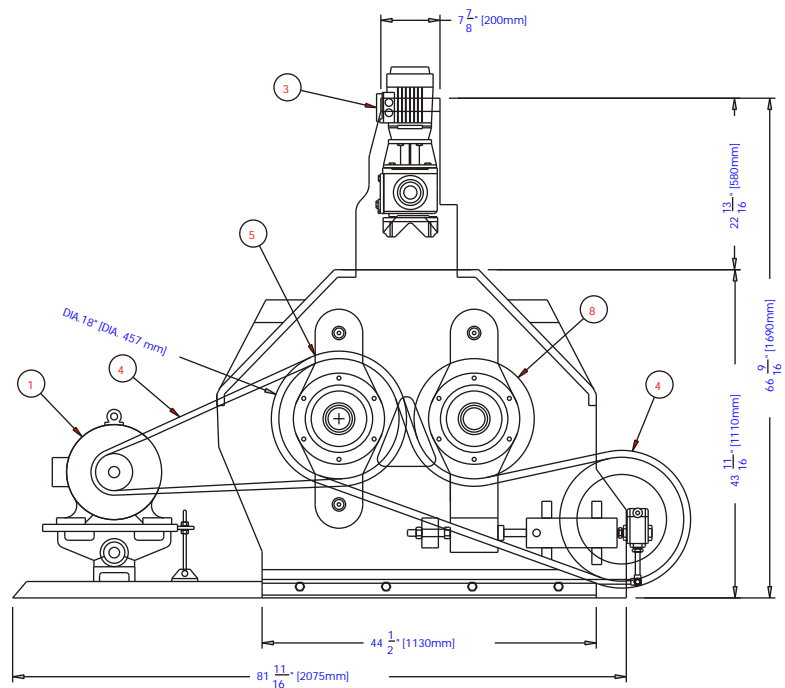
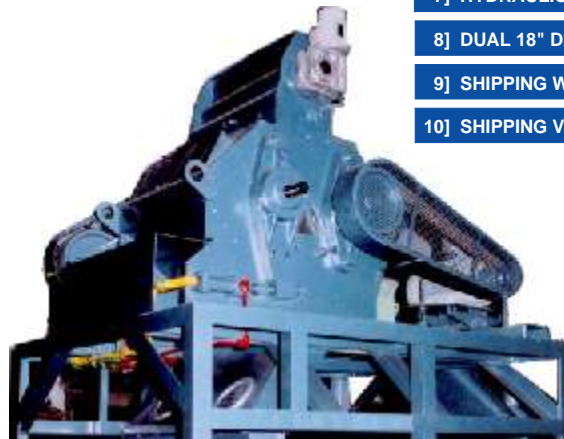

THE 36" TWIN ROLL HULLER & BASKET BEATER / SHAKER IS PRIMARY TO PRODUCE HULLS WITH A MINIMUM OIL CONTENT BY EFFICIENTLY BEATING THE HULLS TO REMOVE THE HIGH PROTEIN FINISHED MEATS.

THE COMBINATION CONSISTS OF AN 36" TWIN ROLL HULLER, EIGHT-CHAMBER BEATER SECTION MOUNTED ABOVE A SHAKER SEPARATOR TRAY.

ALSO Available - 48" Pyxel Huller

WHEN TEAMED UP - you have the most efficient seed hulling & primary removal of hulls from oil bearing seeds on the market today.

## Cottor Plants (India) Pvt. Ltd.

Certified ISO 9001:2000 Company

706, Acme Plaza, Opp. Sangam Talkies, Andheri-Kurla Road, ANDHERI (EAST), MUMBAI - 400059, (INDIA.)  
Tel: +91-22-2826 4201/2/3/4, Fax: +91-22-2834 6161, E-mail: [cottor@vsnl.com](mailto:cottor@vsnl.com), Website: [www.cottor.com](http://www.cottor.com)