

SPECIFICATIONS: FOUR TRAY SEED CLEANER

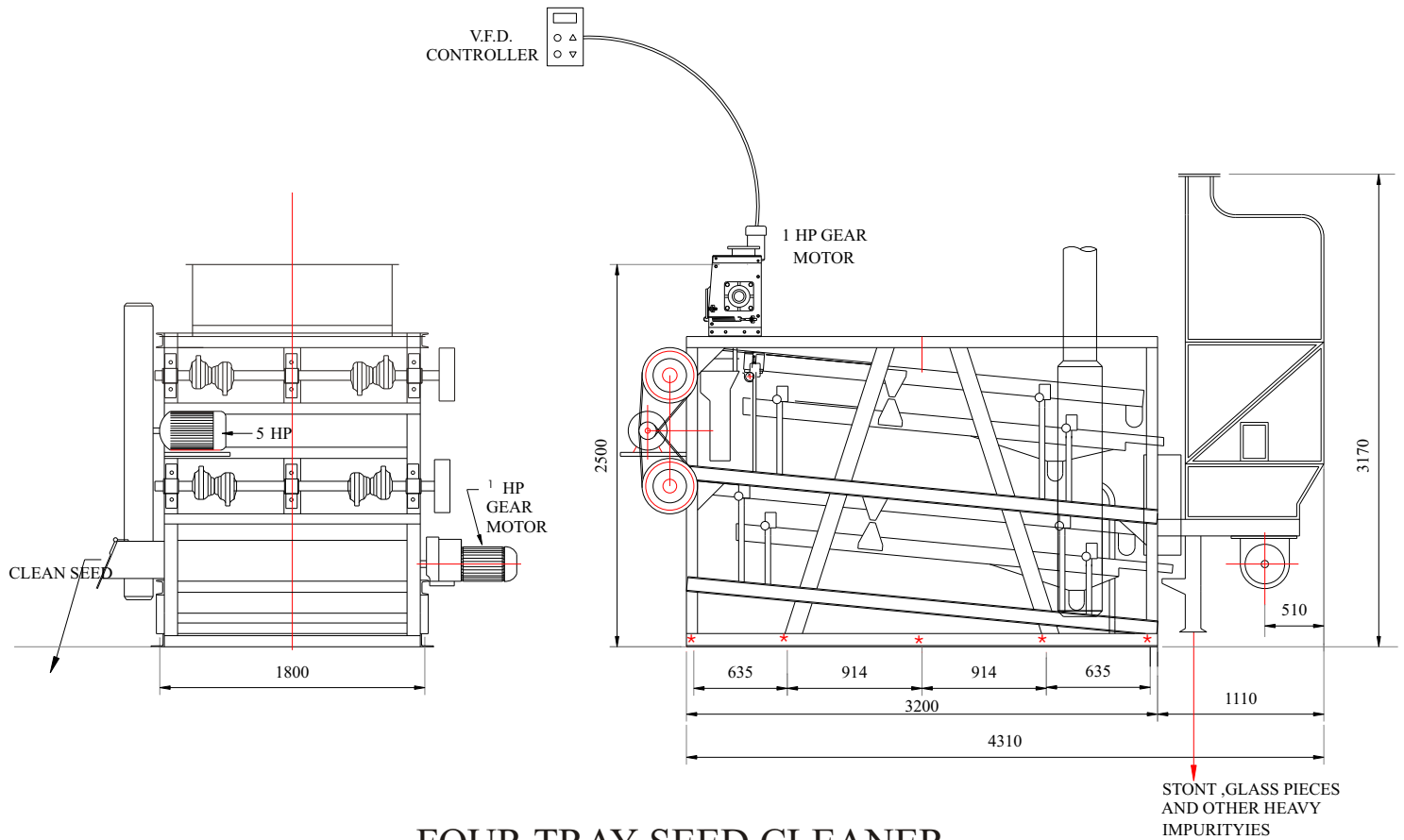

FOUR TRAY SEED CLEANER

The Four Tray Seed Cleaner is sturdy steel fabrication machine having Four Tray reciprocating motion through Eccentric Shaft assembly unit. All steel feeder with volume control feeding by worm gear motor connected to variable frequency drive control panel for feed regulate.

The vacuum chamber is specially designed for easy of operation and maintenance. The blower is mounted on separate structure for better air efficiency & easy attending to top tray.

The unginned seed cotton separated from Tray one and Three collected separately.

The seed from tray two & Four are moved to Vacuum suction chamber which deliver cleaned seed collected through conveyor, separating stone, metal pieces also separating light fly lint and hulls in cyclone.

This perfect cleaning protect other processing machine namely Delinter & Huller.

This Seed Cleaner can be used for multiple seed cleaning application : Cotton Seed , Soybeans, Sunflower Seed, Ground Nut Etc.,

The better cleaning improves quality of by products of cottonseed.

Machine Tray Drive Motor : 5 HP.

Fan Drive Motor : 20 HP.

Discharge Conveyor Motor : 1 HP.

Feeder Drive Motor : 1 HP.

Cottor Plants (India) Pvt. Ltd.

Certified ISO 9001:2000 Company

706, Acme Plaza, Opp. Sangam Talkies, Andheri-Kurla Road, ANDHERI (EAST), MUMBAI - 400059, (INDIA.)
Tel: +91-22-2826 4201/2/3/4, Fax: +91-22-2834 6161, E-mail: cottor@vsnl.com, Website: www.cottor.com