

# SPECIFICATIONS: 60" BEATER / SEPARATOR

## PLAN

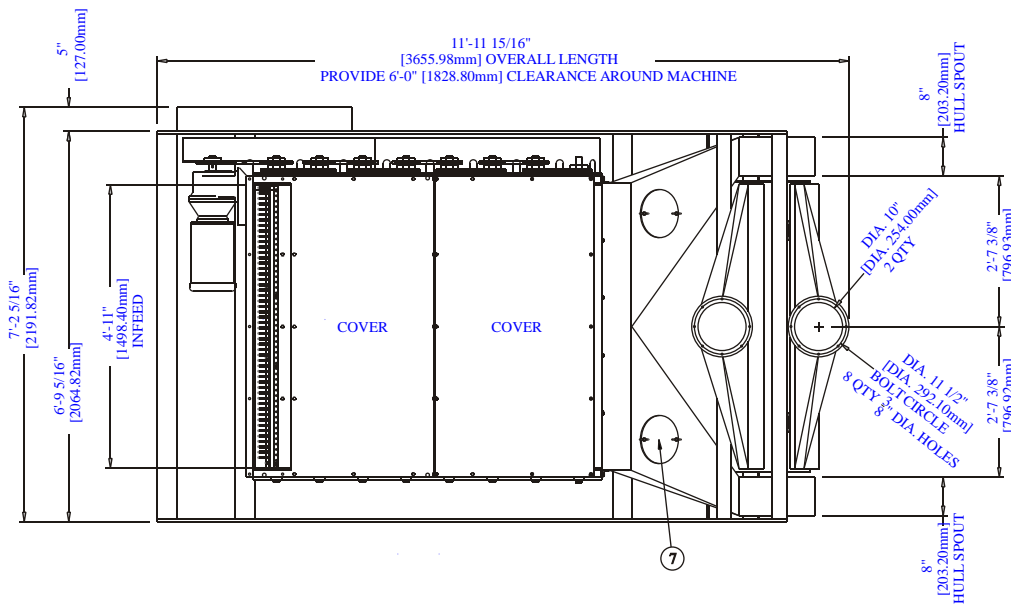

THE COTTOR / CANTRELL BEATER / SHAKER IS PRIMARY TO PRODUCE HULLS WITH A MINIMUM OIL CONTENT BY EFFICIENTLY BEATING THE HULLS TO REMOVE THE HIGH PROTEIN FINISHED MEATS.

THE MACHINE CONSISTS OF AN EIGHT-CHAMBER BEATER SECTION MOUNTED ABOVE A SHAKER SEPARATOR TRAY.

## ELEVATION

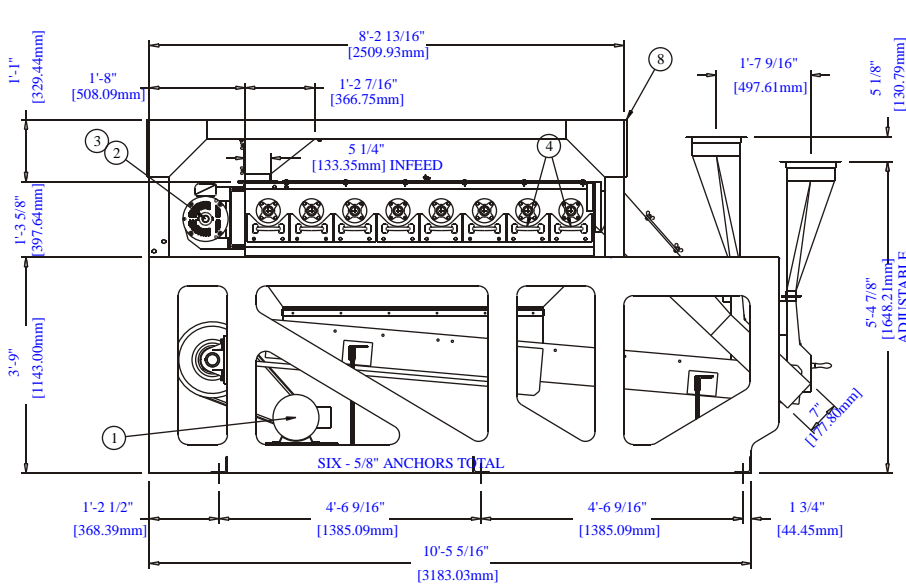

## FRONT

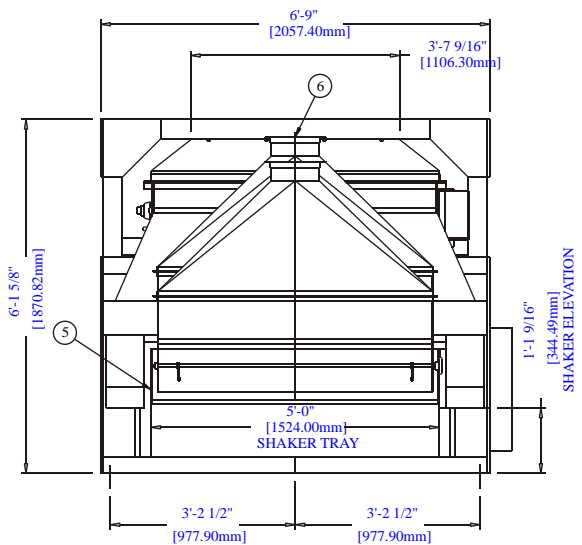

1] SHAKER MOTOR - 3HP - 1000/1200RPM - 380/230-460V / 3PH / 50-60HZ

2] BEATER MOTOR - 5HP - 1450/1750RPM - 380/230-460V / 3PH / 50-60HZ

3] GEAR REDUCER, DOUBLE REDUCTION / HELICAL GEAR 9.3:1

4] 60" EIGHT STATIONARY SCREENS - REMOVABLE

5] SHAKER TRAY - 42.5 SQFT OF SELF CLEANING SASH

6] ADJUSTABLE AIR HOODS - TWO 10" DIA. / 1900 CFM EA. / 3484 FPM

7] INSPECTION WINDOWS - 2 LARGE 10" DIA. VIEWING AREAS

8] UNIVERSAL HULLER STAND / FITS ALL MAKES AND MODELS

9] SHIPPING WEIGHT: 5400 LBS / 2448 KG

10] SHIPPING VOLUME: 512 FT<sup>3</sup> / 14.5 M<sup>3</sup>

## Cottor Plants (India) Pvt. Ltd.

Certified ISO 9001:2000 Company

706, Acme Plaza, Opp. Sangam Talkies, Andheri-Kurla Road, ANDHERI (EAST), MUMBAI - 400059, (INDIA.)

Tel: +91-22-2826 4201/2/3/4, Fax: +91-22-2834 6161, E-mail: [cottor@vsnl.com](mailto:cottor@vsnl.com), Website: [www.cottor.com](http://www.cottor.com)