

SEPECIFICATION

60" EIGHT BASKET BEATER

PLAN

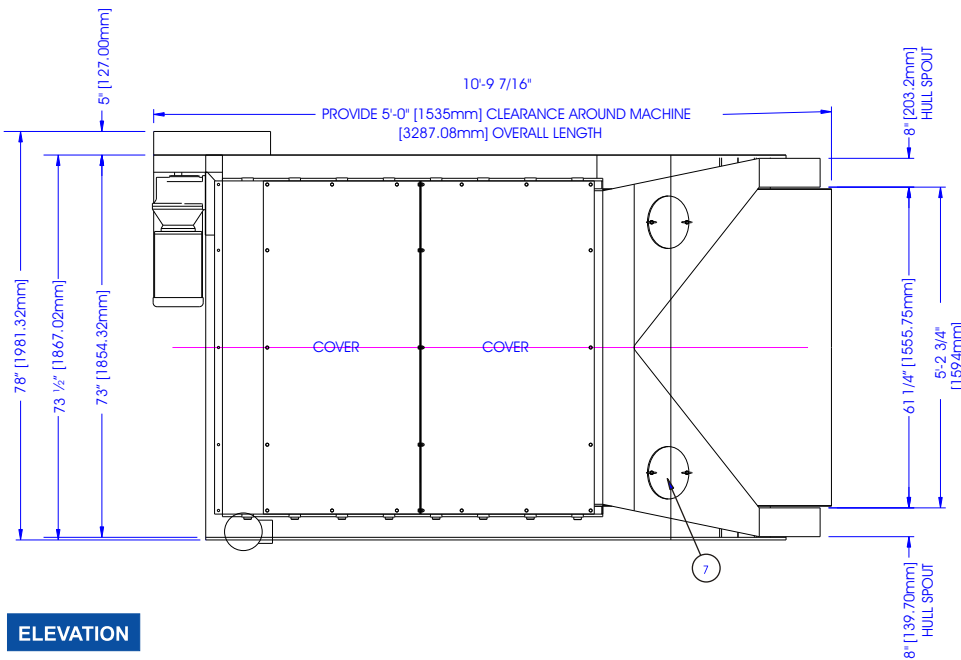

THE COTTOR / CANTRELL BEATER / SHAKER IS DESIGNED TO PRODUCE HULLS WITH A MINIMUM OIL CONTENT BY EFFICIENTLY REMOVING THE HULLS TO REMOTE THE FINE, FLOURY AND SMALL PARTICLES OF MEATSAND OILY LINT.

THE MACHINE CONSISTS OF AN EIGHT-CHAMBER BEATER SECTION MOUNTED ABOVE A SHAKER SEPARATOR TRAY.

ELEVATION

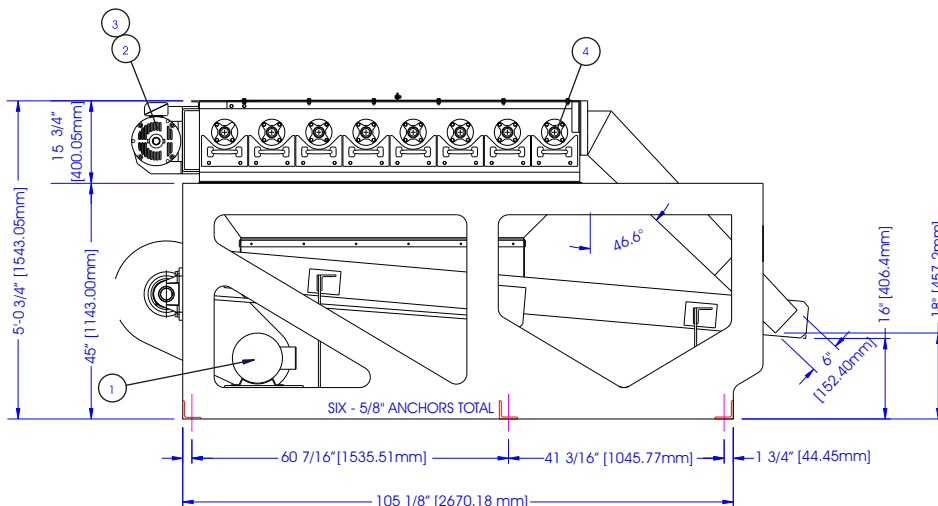

FRONT

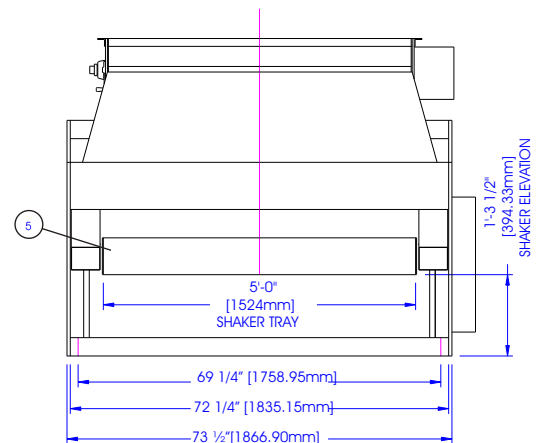

1] SHAKER MOTOR - 2HP-1440/1200 RPM-380/230-440V / 3 PH / 50-60HZ

2] BEATER MOTOR - 2HP-1440/1200 RPM-380/230-440V / 3 PH / 50-60HZ

3] GEAR REDUCER, DOUBLE REDUCTION / HELICAL GEAR 9.3:1

4] 60" EIGHT STATIONARY SCREENS - REMOVABLE

5] SHAKER TRAY - 36 SQ FT OF SELF CLEANING SASH

6] ADJUSTABLE AIR HOOD - 10" DIA. / 1900 CFM / 3484 FPM

7] INSPECTION WINDOWS - 2 LARGE 10" DIA. VIEWING AREAS

8] HEAVY RUGGED \ PLATE CONSTRUCTION

9] SHIPPING WEIGHT: 4500 LBS / 2041 KG

10] SHIPPING VOLUME: 350 FT / 10 M

Cottor Plants (India) Pvt. Ltd.

Certified ISO 9001:2000 Company

706, Acme Plaza, Opp. Sangam Talkies, Andheri-Kurla Road, ANDHERI (EAST), MUMBAI - 400059, (INDIA.)

Tel: +91-22-2826 4201/2/3/4, Fax: +91-22-2834 6161, E-mail: cottor@vsnl.com, Website: www.cottor.com