

BOX TYPE SEED CLEANER



SOYABEAN

MAIZE

RAP SEED

RICE

GRAIN

COFFEE

BEANS

SEEDS

SUNFLOWER
SEED

NUTS

Other Products

UNIQUE FEATURES

- SIMPLE DESIGN & STURDY MODERN CONSTRUCTION.
- BETTER CLEANING EFFICIENCY.
- LOW MAINTENANCE COST.
- SIMPLE ADJUSTMENT & EASY OPERATION.
- DUST FREE & LOW NOISE OPERATION.
- HIGHER CAPACITY.

This new design totally enclosed seed cleaner is an all purpose cleaner designed for efficient separation of impurities from Soyabean, Maize, Sunflower seed, Rap seed, Rice, Grain, Coffee, Beans, Seeds, Nuts & Others Products.

This new design seed cleaning machine is available with an aspirator unit, for dust free atmosphere in the plant room. This increases operating efficiency.

Cottor Plants (India) Pvt. Ltd.

Certified ISO 9001:2015 Company

706, Acme Plaza, Opp. Sangam Talkies, Andheri-Kurla Road,
Andheri (East), Mumbai - 400059, (INDIA.)

Tel: +91-22-2826 4201/2/3/4,

E-mail: cottorindia@cottor.com, Website: www.cottor.com



SPECIFICATIONS: BOX TYPE SEED CLEANER.

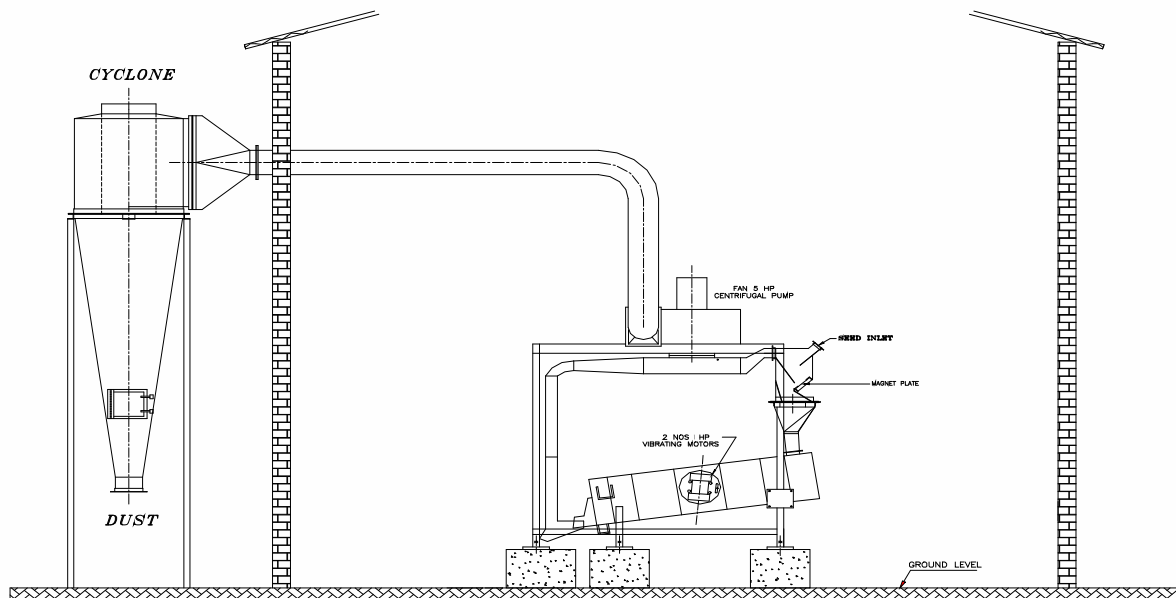
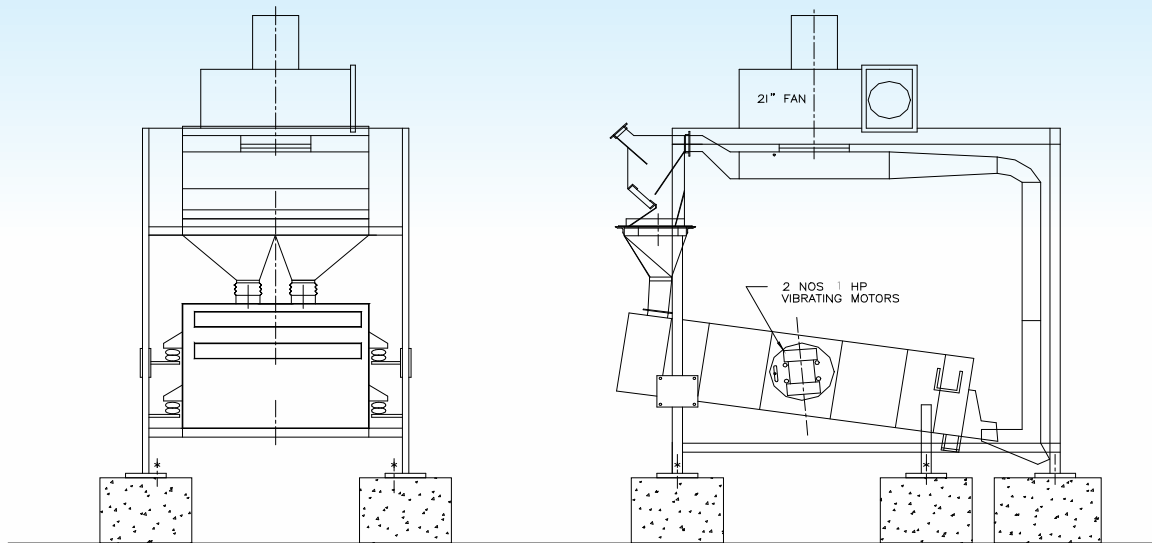

SEED CLEANER HIGH CAPACITY WITH ASPIRATION SYSTEM.

OPERATION :

The material is fed into the inlet chute of the cascade hopper installed above Seed cleaner machine and distributed across the width of the upper tray.

Two vibratory motors fitted on either side of machine develop vibratory movement to enable the material to move on the tray and pass through the perforated screen.

The trays having rubber balls for self cleaning of perforated screen holes.

All big impurities are separated from the top tray from chute "A" and fine dust From the bottom tray chute "B"

The cleaned seed collected at the front of the machine through the air aspirator, after air washing of the material for further process.