



# Cottor Plants (India) Pvt. Ltd.

Certified ISO 9001:2015 Company

**COTTOR** IS PROUD TO HAVE ENTERED INTO TECHNICAL COLLABORATION WITH



**CANTRELL  
WORLDWIDE INC.**

4292 Hwy 377, Suite 25, Aubrey, Dallas, Texas 76227, USA  
PHONE: +1-972-302-2557 FAX: +1-214-279-0855  
Email:- ayush@cantrellworldwide.com, rdb@cantrellworldwide.com  
WEB:- www.cantrellworldwide.com

*To Manufacture & Supply under licence  
Latest design, High capacity,  
State of art modern technology,  
Excellent performance,  
Cotton Seed processing machinery & parts  
For Vegetable Oil industries.*

## **NEW 7 STAGE LINT CLEANER.**

*Utilizing 'Laminar Flow' cleaning,  
for the highest recovery of quality  
lint in the industry.*

*Extra large capacity reclaim section  
for high secondary lint recovery.*

*Beater screens mounted in easy-pull  
trays for quick change and ease of  
maintenance.*

*Clean rugged design with heavy  
structural construction for smooth  
operation.*

*Total control of bran, meats and other  
oily by-products removed from lint stream.*

*Advanced powdered metal finish for easy  
clean-up and long lasting appeal.*

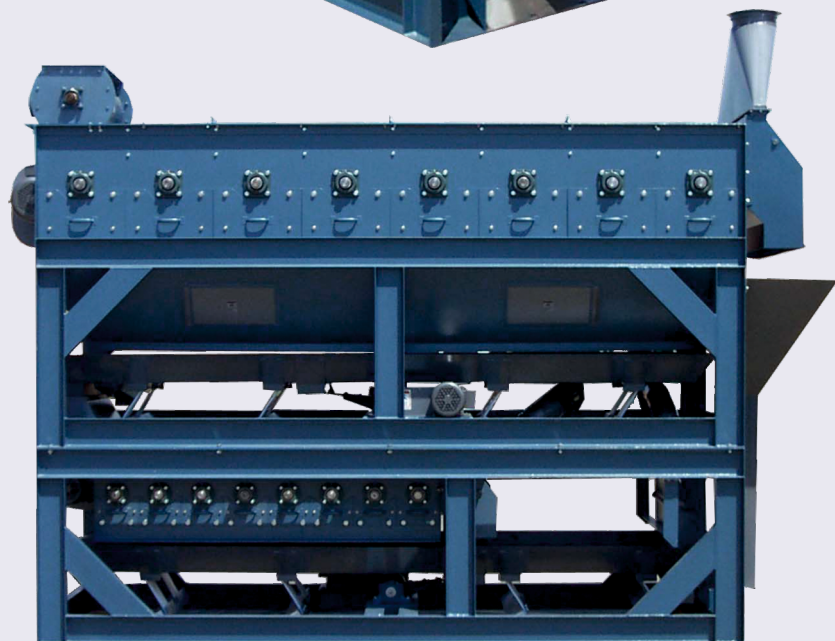

# SPECIFICATIONS: 7 STAGE LINT CLEANER

## PLAN

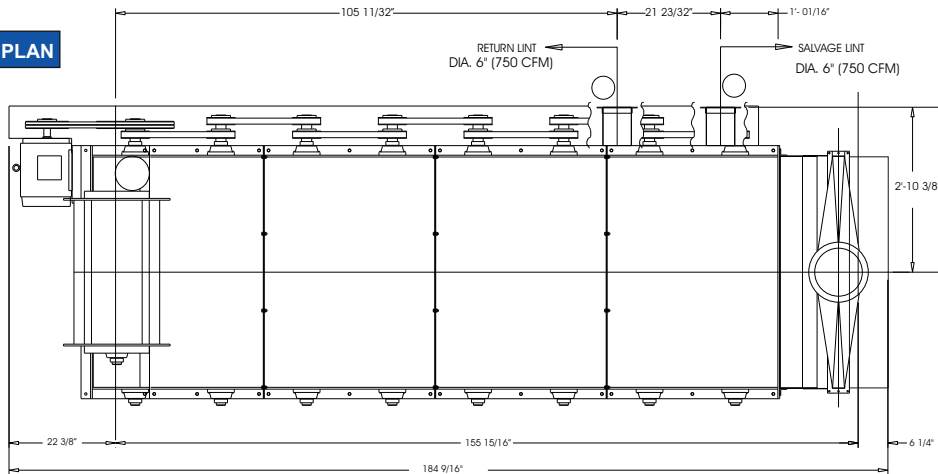

THE COTTOR / CANTRELL 7 STAGE LINT CLEANER WILL PROVIDE THE HIGHEST CAPACITY AND RECOVERY OF LINT ON THE MARKET TODAY, WHILE MAINTAINING THE HIGHEST LINT QUALITY AVAILABLE.

LAMINAR FLOW CLEANING GENTLY FLUFFS THE LINT WHILE REMOVING THE CONTAMINATES WITH LITTLE OR NO DAMAGE TO FIBER.

LARGE PEPPER AND BRAN SECTION ELIMINATES OIL, MEATS, AND HULL BRAN EARLY TO KEEP OIL ABSORPTION AND DISCOLORATION IN FINISHED LINT TO A MINIMUM.

## ELEVATION

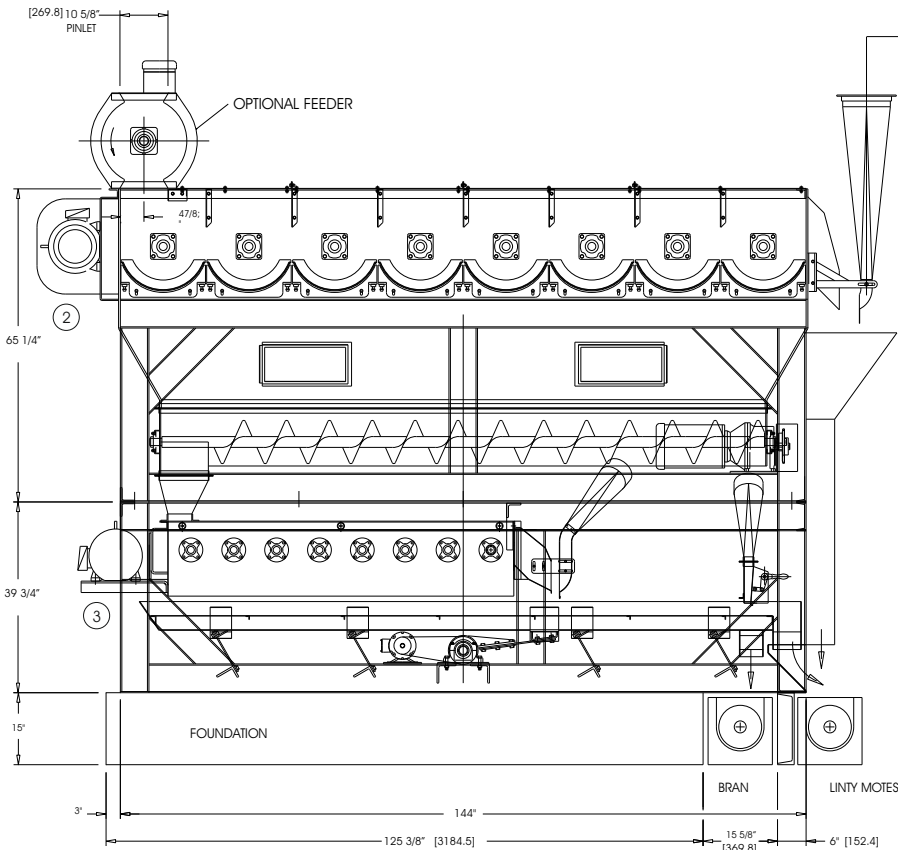

## FRONT

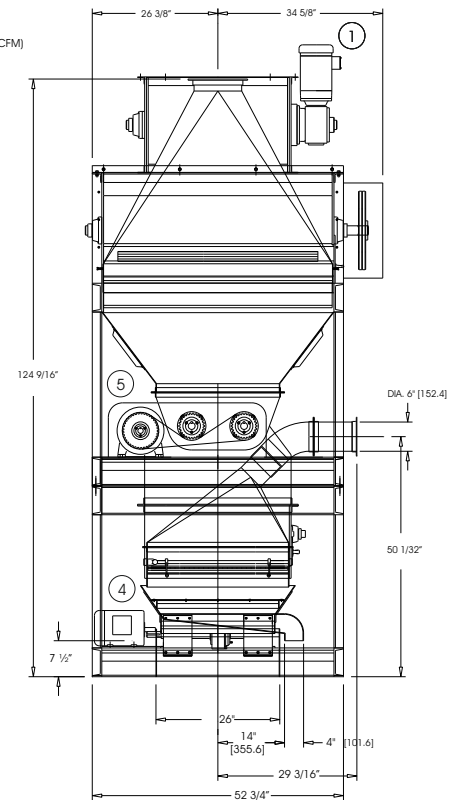

1] FEEDER MOTOR - 1.5HP - 1450/1750RPM - 380/230-460V / 3PH / 50-60HZ

2] BEATER MOTOR - 7.5HP - 1000/1200RPM - 380/230-460V / 3PH / 50-60HZ

3] BEATER MOTOR - 2HP - 1450/1750RPM - 380/230-460V / 3PH / 50-60HZ

4] SHAKER MOTORS - 1HP - 1000/1200RPM - 380/230-460V / 3PH / 50-60HZ

5] TWIN CONVEYOR - 2 HP - 1450/1750 RPM - 380/230-460 V AC, 50-60 HZ

6] AIR HOOD - 10" DIA. / 1600 CFM / 2934 FPM VELOCITY

7] CAPACITY 30,000 LBS / 13,610 KG PER 24 HOUR DAY

8] 48" (1219mm) WIDE CELLULOSE SEC. 30" (762mm) WIDE RECLAIM SEC.

9] SHIPPING WEIGHT: 11,800 LBS / 5,352 KG

10] SHIPPING VOLUME: 603 FT / 17 M

## Cottor Plants (India) Pvt. Ltd.

Certified ISO 9001:2015 Company

706, Acme Plaza, Opp. Sangam Talkies, Andheri-Kurla Road, ANDHERI (EAST), MUMBAI - 400059, (INDIA.)

Tel: +91-22-2826 4201/2/3/4, E-mail: [cottorindia@cottor.com](mailto:cottorindia@cottor.com), Website: [www.cottor.com](http://www.cottor.com)