



Cottor Plants (India) Pvt. Ltd.

Certified ISO 9001:2015 Company

COTTOR IS PROUD TO HAVE ENTERED INTO TECHNICAL COLLABORATION WITH



**CANTRELL
WORLDWIDE INC.**

4292 Hwy 377, Suite 25, Aubrey, Dallas, Texas 76227, USA
PHONE: +1-972-302-2557 FAX: +1-214-279-0855
Email:- ayush@cantrellworldwide.com, rdb@cantrellworldwide.com
WEB:- www.cantrellworldwide.com

*To Manufacture & Supply under licence
Latest design, High capacity,
State of art modern technology,
Excellent performance,
Cotton Seed processing machinery & parts
For Vegetable Oil industries.*

NEW... 176 & 200 SAW FILER

The performance of your lint room is critical to maintaining quality lint at the highest capacity obtainable. Nothing controls your lint quality and capacity as a good sharp saw tooth, and nothing controls a good sharp saw tooth as your precision saw filer. So it stands to reason that you want the best saw filer obtainable for your operation. Well here it is!

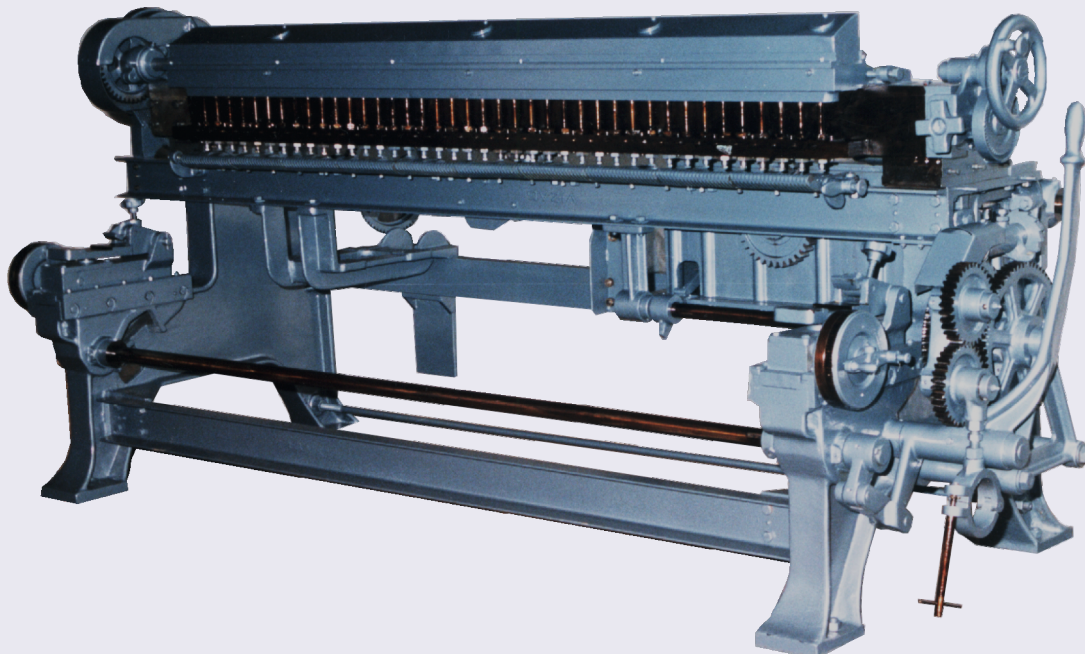
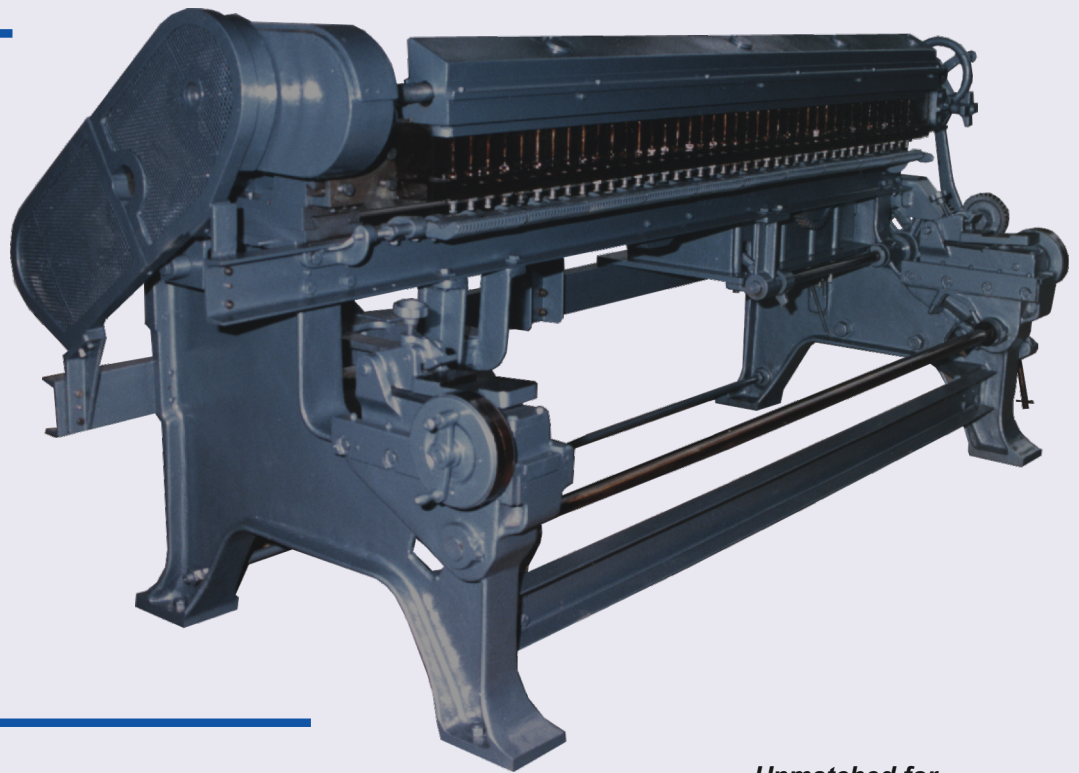

Unmatched for precision and performance in maintaining quality uniform teeth, throughout the life of your saws.

Completely automatic saw filer with machine tool accuracy.

Ruggedly built for smooth operation and reliability.

Completely interchangeable parts for low maintenance and service ease.

SPECIFICATIONS: 176 & 200 SAW FILER

PLAN

THE COTTOR / CANTRELL 176 & 200 SAW FILER MAINTAINS SAWS IN PERFECT CONDITION AT ALL TIMES. THE CANTRELL SAW FILER HAS MACHINE TOOL PRECISION THAT WILL CUT IN AND MAINTAIN A GOOD TOOTH PROFILE THROUGHOUT THE LIFE OF THE SAWS.

COTTOR / CANTRELL HAS DEVELOPED MANY IMPROVEMENTS TO THE SAW SHARPENING PROCESS INCLUDING A BRAND NEW "ENGINEERED" SAW FILE.

THE NEW SAW FILE COMBINED WITH THE NEW SAW FILER CREATES AN ENHANCED TOOTH PROFILE THAT PROMOTES HIGHER DELINTING CAPACITIES.

THE SAW FILER IS DESIGNED TO PROVIDE EXTRA LONG LIFE WHILE MAINTAINING QUALITY AND CONSISTENCY NEVER BEFORE ACHIEVED.

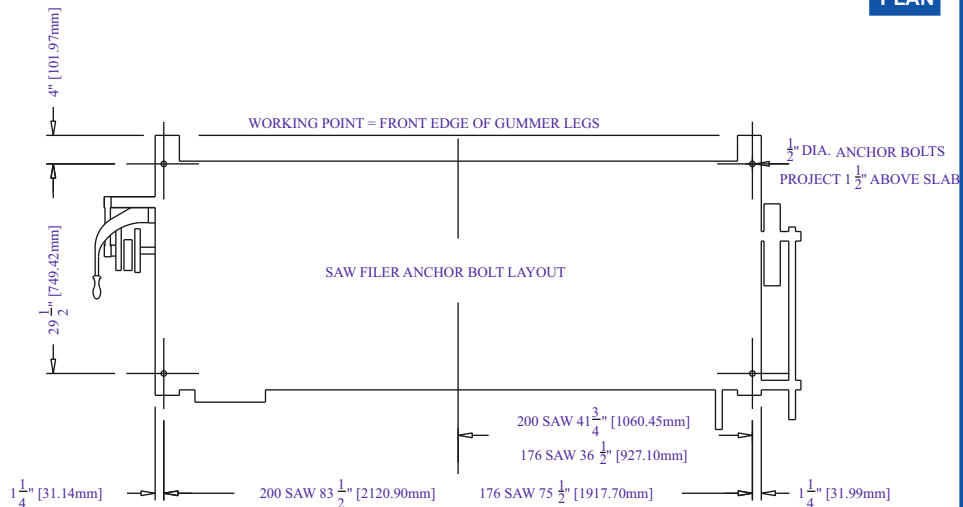

FRONT

ELEVATION

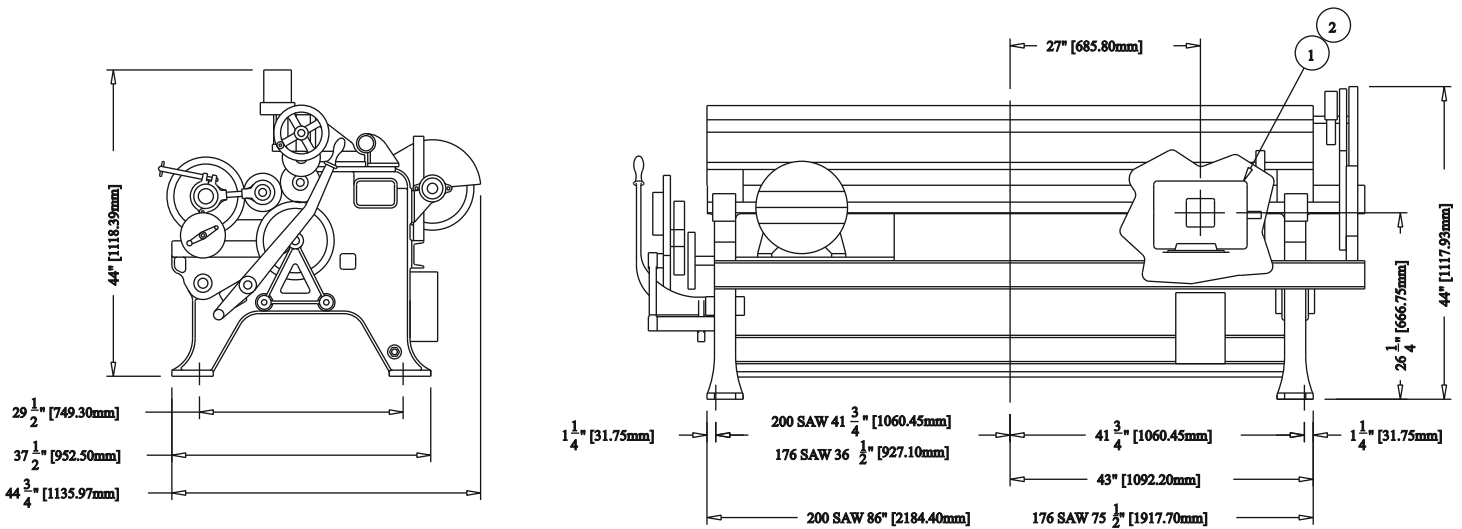

- 1] 176 SAW DRIVE MOTOR - 3 HP - 50 HZ / 2 HP - 60 HZ
- 2] 200 SAW DRIVE MOTOR - 5 HP - 50 HZ / 3 HP - 60 HZ
- 3] SHIPPING WEIGHT: (176) 1930 LBS / 875.4KG (200) 2150 LBS / 975.2KG
- 4] SHIPPING VOLUME: (176) 145 FT / 4.1 M (200) 160 FT / 4.5 M
- 5] CANTRELL PROVIDES A COMPLETE LINE OF PARTS AND ACCESSORIES



Cottor Plants (India) Pvt. Ltd.

Certified ISO 9001:2015 Company

706, Acme Plaza, Opp. Sangam Talkies, Andheri-Kurla Road, ANDHERI (EAST), MUMBAI - 400059, (INDIA.)

Tel: +91-22-2826 4201/2/3/4, E-mail: cottorindia@cottor.com, Website: www.cottor.com