



Cottor Plants (India) Pvt. Ltd.

Certified ISO 9001:2015 Company

COTTOR IS PROUD TO HAVE ENTERED INTO TECHNICAL COLLABORATION WITH



**CANTRELL
WORLDWIDE INC.**

4292 Hwy 377, Suite 25, Aubrey, Dallas, Texas 76227, USA
PHONE: +1-972-302-2557 FAX: +1-214-279-0855
Email:- ayush@cantrellworldwide.com, rdb@cantrellworldwide.com
WEB:- www.cantrellworldwide.com

To Manufacture & Supply under licence
**Latest design, High capacity,
State of art modern technology,
Excellent performance,
Cotton Seed processing machinery & parts
For Vegetable Oil industries.**

NEW...

200 SAW "HIGH PERFORMANCE" DELINTE

NO AIR IDLERS REQUIRED

POSITIVE MANUAL ADJUSTMENT OF SAW MOTOR DRIVE.

TWIN GRATEFALL CYLINDERS

*ADD BALANCE TO OPENING AND SIT BACK OUT
OF THE AISLE TO PREVENT DAMAGE.*

**MOTORS LOCATED FOR EASY
ACCESS**

*ALLOW FOR WELL VENTILLATED
COOL RUNNING.*

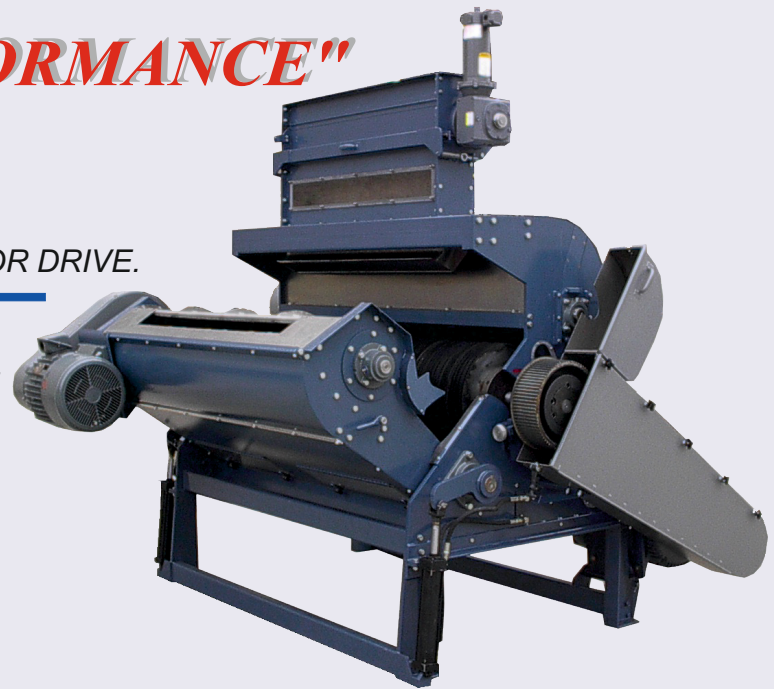

NEW DESIGN FLOAT CYLINDER

RUGGED HIGH PERFORMANCE & LOW MAINTENANCE.

RUGGED ALUMINUM SAW PULLEY

ALLOWS FOR EASY REMOVAL (28 LBS).

EXTENDED SEED CHARGING CHAMBER

*CREATES EXTRA DENSITY IN FLOAT FOR A
MORE UNIFORM LINT CUT WITH NO SEED
MESS.*

LOW PROFILE

*LOW CENTER OF GRAVITY MAKES
SMOOTH RUNNING AND EASY
TO REACH OPERATION &
MAINTENANCE.*

HEAVY GAUGE DRIVE GUARDS

WITH EASY ACCESS TO DRIVES.

ADVANCED POWDERED METAL FINISH

MAKES FOR EASY CLEAN-UP AND LONG LASTING APPEAL.

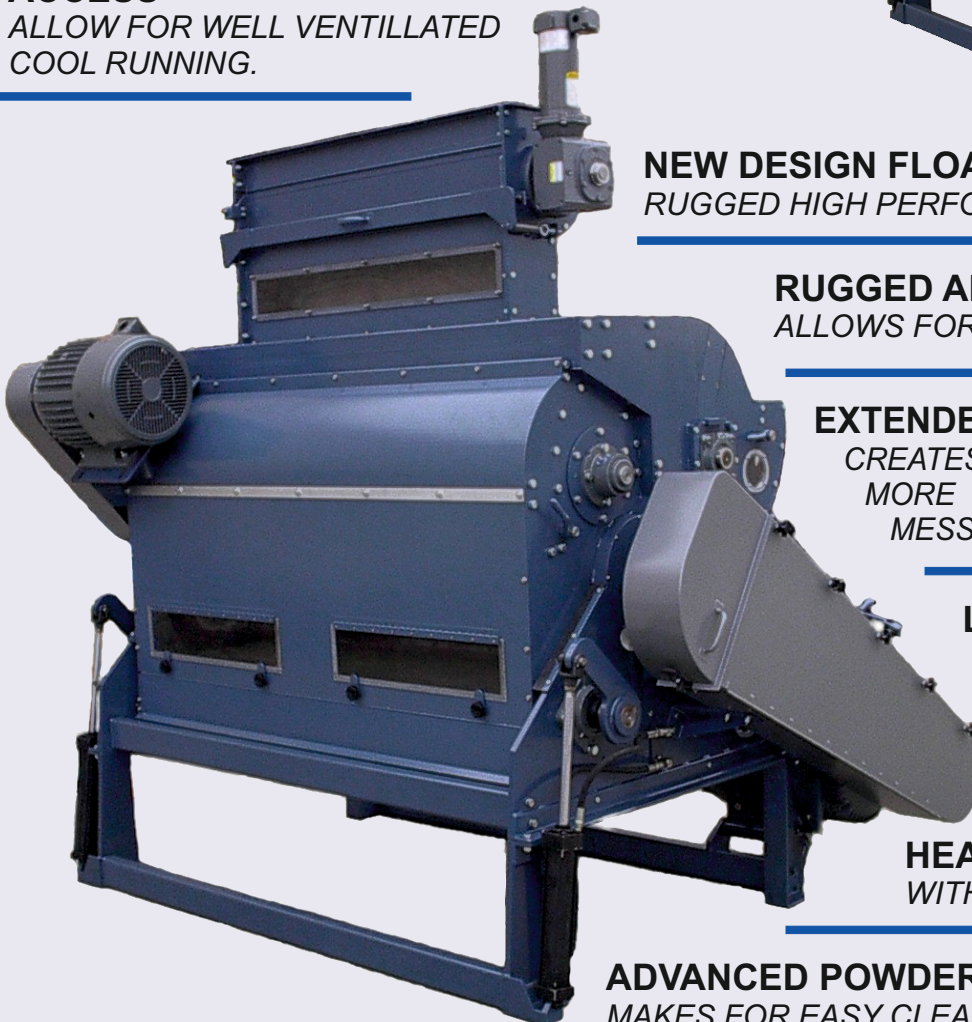

SPECIFICATIONS: 200 SAW DELINER

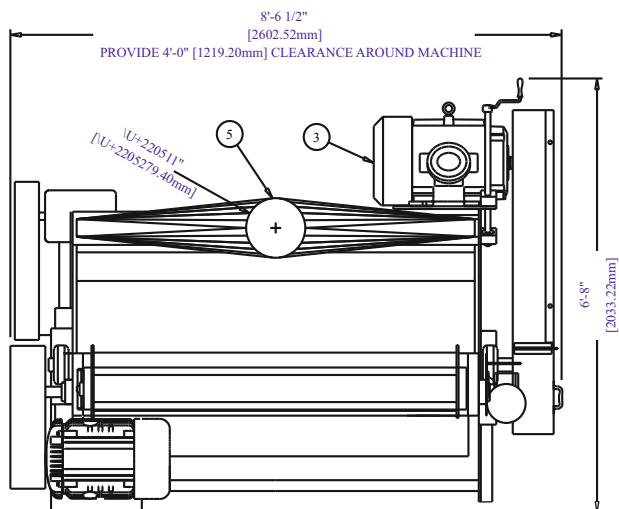

THE NEW COTTOR / CANTRELL 200 SAW DELINER COMBINES THE HIGHEST CAPACITY LINT REMOVAL WITH THE LOWEST MAINTENANCE REQUIRED FOR ANY DELINER ON THE MARKET TODAY.

THE EXTREMELY LOW PROFILE MAKES FOR EASY ADJUSTMENTS WHILE ALLOWING FOR SMOOTH TROUBLE FREE OPERATION. MONITORING THE DELINERS' PERFORMANCE HAS NEVER BEEN EASIER WITH EXTRA LARGE INSPECTION WINDOWS AT THE MOST CRITICAL LOCATIONS.

HIGH PERFORMANCE, QUALITY LINT, RELIABILITY AND SAFETY ARE THE BEST REASONS FOR PURCHASING THIS NEW SAW DELINER.

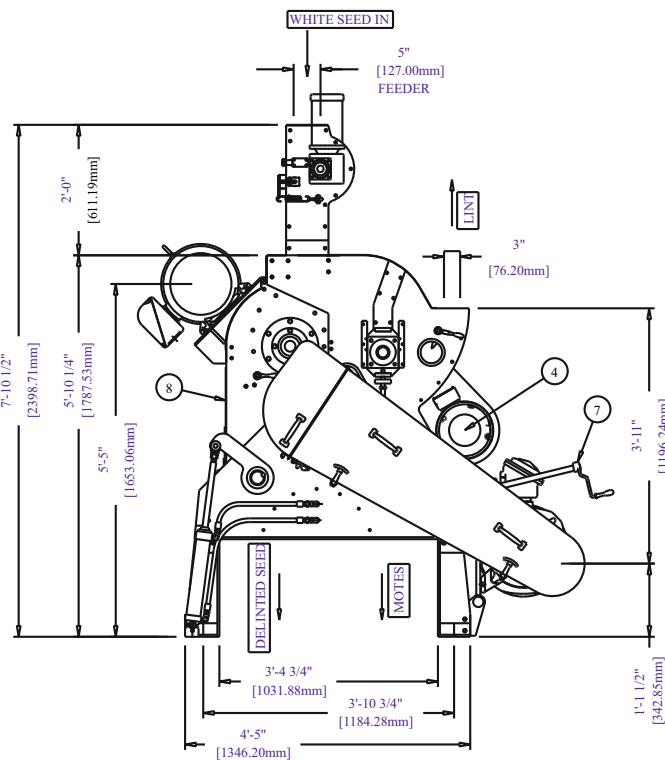
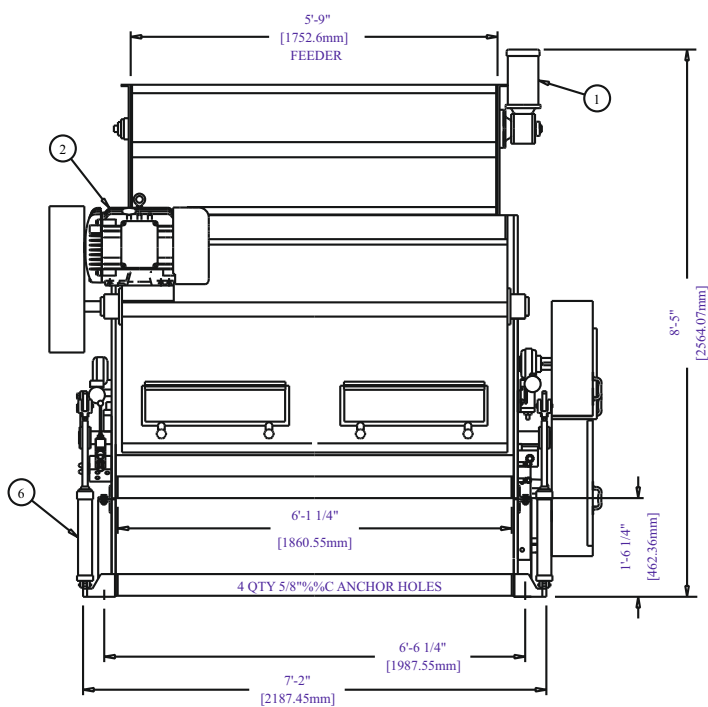

- 1] FEEDER MOTOR - 1 HP - 380/230-440V / 3PH / 50-60HZ
- 2] FLOAT MOTOR - 25 HP - 1450/1750RPM - 380/230-440V / 3PH / 50-60HZ
- 3] SAW MOTOR - 40 HP - 1450/1750RPM - 380/230-440V / 3PH / 50-60HZ
- 4] BRUSH MOTOR - 3 HP - 1450/1200RPM - 380/230-440V / 3PH / 50-60HZ
- 5] LINT AIR HOOD - 11" DIA. / 2200 CFM / 3340 FPM VELOCITY

- 6] DUAL GRATEFALL ASSIST HYDRAULIC CYLINDERS (600 PSI)
- 7] POSITIVE MECHANICAL BELT TENSIONING
- 8] 200 - 18" DIA. X .045" SAWS ON 7 15/16" DIA. CYLINDER
- 9] SHIPPING WEIGHT: 6800 LBS / 3084 KG
- 10] SHIPPING VOLUME: 477 FT³ / 13.59 M³

Cottor Plants (India) Pvt. Ltd.

Certified ISO 9001:2015 Company

706, Acme Plaza, Opp. Sangam Talkies, Andheri-Kurla Road, ANDHERI (EAST), MUMBAI - 400059, (INDIA.)
Tel: +91-22-2826 4201/2/3/4, E-mail: cottorindia@cottor.com, Website: www.cottor.com