



Cottor Plants (India) Pvt. Ltd.

Certified ISO 9001:2015 Company

COTTOR IS PROUD TO HAVE ENTERED INTO TECHNICAL COLLABORATION WITH



**CANTRELL
WORLDWIDE INC.**

4292 Hwy 377, Suite 25, Aubrey, Dallas, Texas 76227, USA
PHONE: +1-972-302-2557 FAX: +1-214-279-0855
Email:- ayush@cantrellworldwide.com, rdb@cantrellworldwide.com
WEB:- www.cantrellworldwide.com

To Manufacture & Supply under licence
**Latest design, High capacity,
State of art modern technology,
Excellent performance,
Cotton Seed processing machinery & parts
For Vegetable Oil industries.**

NEW...

60" BEATER / SEPARATOR

The most efficient primary removal of hulls from oil bearing seeds on the market today.

The Beater Separator combines mechanical and pneumatic forces to effectively remove hulls from decorticated oil bearing seeds, including cottonseed, sunflower, soybeans, peanuts, etc.

Solidly designed and built for most generic hullers to be mounted over the frame.



Features include;

Self cleaning aluminum sash for level constant results.

Extra heavy duty eccentrics for smooth operation and long life.



Beater screens mounted in easy-pull trays for quick change and ease of maintenance.

SPECIFICATIONS: 60" BEATER / SEPARATOR

PLAN

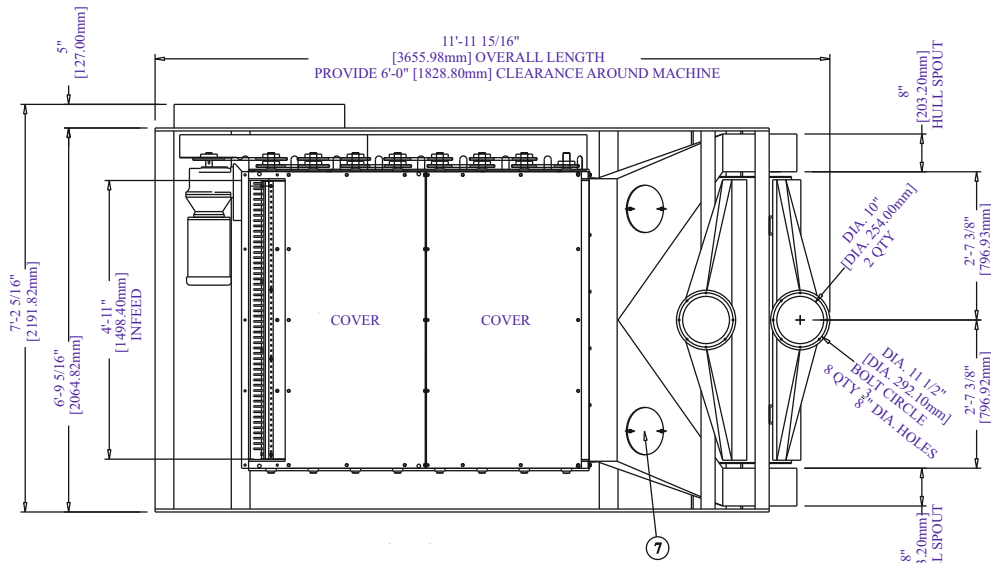

THE COTTOR / CANTRELL BEATER / SHAKER IS PRIMARY TO PRODUCE HULLS WITH A MINIMUM OIL CONTENT BY EFFICIENTLY BEATING THE HULLS TO REMOVE THE HIGH PROTEIN FINISHED MEATS.

THE MACHINE CONSISTS OF AN EIGHT-CHAMBER BEATER SECTION MOUNTED ABOVE A SHAKER SEPARATOR TRAY.

ELEVATION

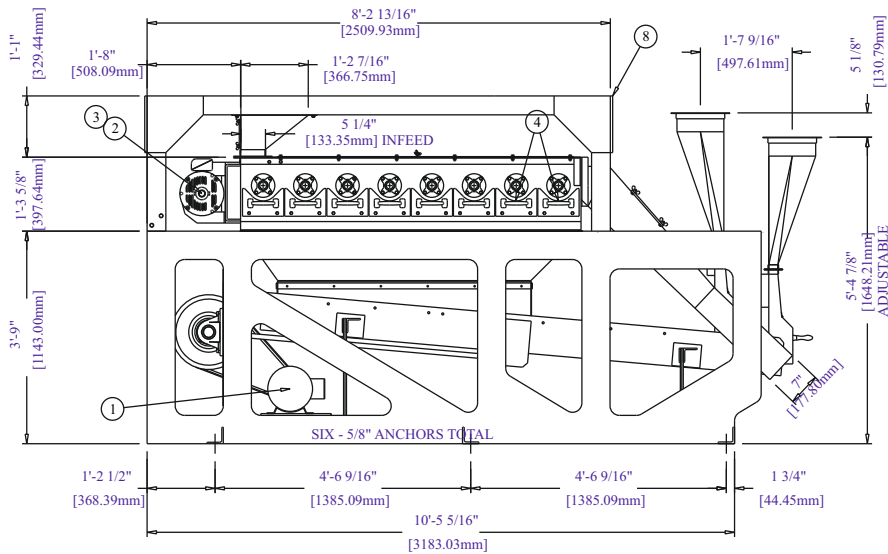

FRONT

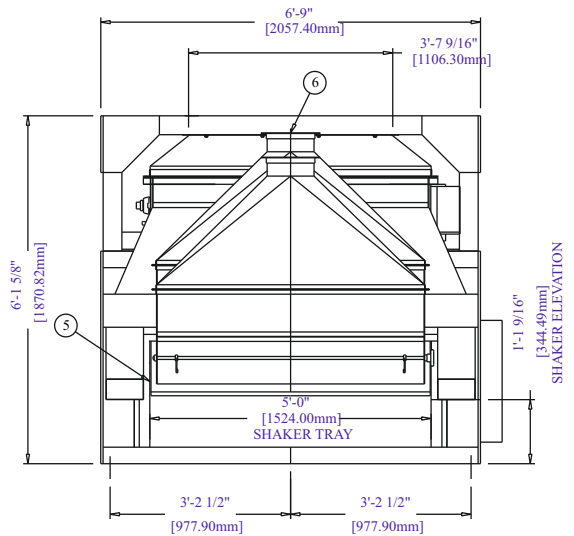

1] SHAKER MOTOR - 2HP-1440/1200 RPM-380/230-440V / 3 PH / 50-60HZ

2] BEATER MOTOR - 5HP - 1450/1750RPM - 380/230-460V / 3PH / 50-60HZ

3] GEAR REDUCER, DOUBLE REDUCTION / HELICAL GEAR

4] 60" EIGHT STATIONARY SCREENS - REMOVABLE

5] SHAKER TRAY - 42.5 SQFT OF SELF CLEANING SASH

6] ADJUSTABLE AIR HOODS - TWO 10" DIA. / 1900 CFM EA. / 3484 FPM

7] INSPECTION WINDOWS - 2 LARGE 10" DIA. VIEWING AREAS

8] UNIVERSAL HULLER STAND / FITS ALL MAKES AND MODELS

9] SHIPPING WEIGHT: 5400 LBS / 2448 KG

10] SHIPPING VOLUME: 512 FT / 14.5 M

Cottor Plants (India) Pvt. Ltd.

Certified ISO 9001:2015 Company

706, Acme Plaza, Opp. Sangam Talkies, Andheri-Kurla Road, ANDHERI (EAST), MUMBAI - 400059, (INDIA.)

Tel: +91-22-2826 4201/2/3/4, E-mail: cottorindia@cottor.com, Website: www.cottor.com